

# ATR 60 P ATR 68 P

PREMIUM RAMMERS



## BUILT TO MEET THE HIGHEST STANDARDS

The Premium ATR 60 P and ATR 68 P rammers are built to fulfill the highest demands in both performance and operator safety. The petrol driven Honda GXR 120 engine delivers the needed power while fulfilling all emission regulations. New features include a new, multifunctional gas lever and an additional air filter, for longer life and extended service intervals.

### EXCELLENT DRIVE

- Low centre of gravity improves balance, prevents tipping and makes machine guidance easy
- Best-in-class forward-moving abilities thanks to superior machine balance

### USER FRIENDLY HANDLE

- Limits vibration to operator and reduces fatigue
- Adjustable in height to make the operator more comfortable
- Enables machine to be held and operated from all sides to reach tight areas and work in narrow spaces
- Open handle bar allows to view the foot at any time

### CONVENIENT AIR FILTRATION

- High-performance air filter is fixed horizontal in a secure position and can be maintained without any tools
- Optional available cyclone pre-filter with low pressure indicator helps filters last 5 times longer

### THE SHOE FITS

- Standard 280 mm foot
- Seven shoe sizes available including an asymmetric option for compaction along walls and curbs
- Wear-resistant ramming shoe with integrated steel plate
- Shoes can be switched by removing only four screws
- Light guide tube assembly

### APPLICATIONS

- Trench compaction
- Back filling
- Pipe work
- Foundation work
- Patch work on roads
- Confined areas

**AMMANN**

TECHNICAL SPECIFICATIONS  
 ATR 60 P / ATR 68 P PREMIUM RAMMERS

**WEIGHT & DIMENSIONS**

	ATR 60 P	ATR 68 P
MACHINE WEIGHT	62 kg (137 lb)	68 kg (150 lb)
A FOOT LENGTH	340 mm (13.4 in)	340 mm (13.4 in)
B FOOT WIDTH	280 mm (11 in)	280 mm (11 in)
C HANDLE LENGTH	710 mm (28 in)	710 mm (28 in)
D MACHINE HEIGHT	1020 mm (40.2 in)	1020 mm (40.2 in)
E HANDLE WIDTH	355 mm (14 in)	355 mm (14 in)

**ENGINE**

	Honda GXR 120	Honda GXR 120
ENGINE	Honda GXR 120	Honda GXR 120
FUEL	Petrol	Petrol
ENGINE OUTPUT AT RPM	2.7 kW (3.7 HP) 4300	2.7 kW (3.7 HP) 4300

**COMPACTION FORCES**

PERCUSSION RATE	680 bpm	680 bpm
STROKE HEIGHT	65 mm (2.6 in)	65 mm (2.6 in)
CENTRIFUGAL FORCE	11.5 kN (2,6 lbf)	13 kN (2.9 lbf)
SURFACE CAPACITY	225 m <sup>2</sup> /h (2422 ft <sup>2</sup> /h)	225 m <sup>2</sup> /h (2422 ft <sup>2</sup> /h)
MAX. COMPACTION PERFORMANCE*	45 cm (18 in)	50 cm (18 in)

**MISCELLANEOUS**

FUEL TANK CAPACITY	3.2 l (0.8 gal)	3.2 l (0.8 gal)
TRAVEL SPEED	13.5 m/min (0.5 mph)	13.5 m / min (0.5 mph)
OPTIONAL FOOT SIZES WIDTH	165–200–230–330–400 mm (6.5–7.87–9.1–13–16 in)	165–200–230–330–400 mm (6.5–7.87–9.1–13–16 in)

\*depending on ground conditions

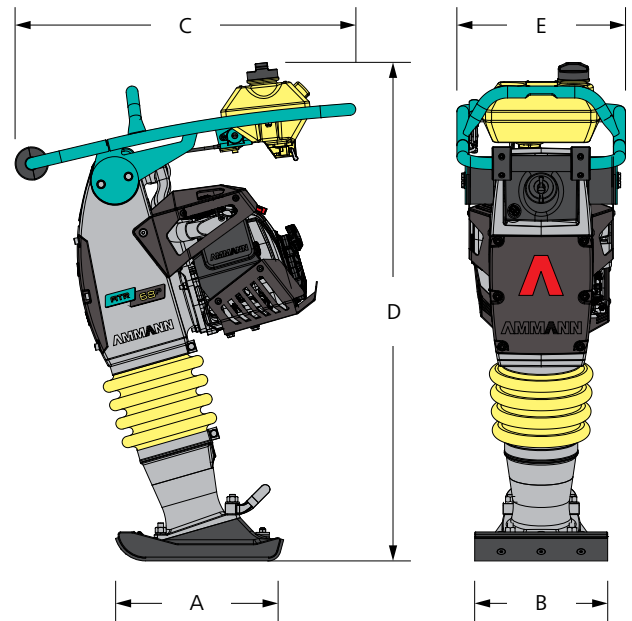

**STANDARD EQUIPMENT**

- Multifunctional gas throttle
- Additional air filter system
- Vibration isolated guide handle
- Carburetor with integrated accelerator pump for trouble free quick engine start
- Oil alert system with LED indicator
- Large fuel tanks
- High quality, wear resistant 280 mm base plate
- Honda engine with reliable starter
- Convenient rolls for easy loading and unloading
- Petrol engine requires no fuel mixing at the job site

**OPTIONAL EQUIPMENT**

- Adaptor plate for 10 cm height reduction
- Cyclone pre cleaner for air filter extends lifetime of the filter by 5 times
- Seven different sized foot plates from 165 mm to 400 mm
- 340 mm asymmetric foot plate for compaction up to walls and curbs
- Transport wheels
- Operation hour meter